



The compact and sleek PEGASUS is perfect for a minimalist approach to workstation design and connectivity within the office.

PEGASUS takes up less than 50mm of desk space yet used in conjunction with our current QIKFIT range, PEGASUS provides a comprehensive solution for power, TUF charging, data and AV connectivity at the workstation.

Available in 2 standard sizes, PEGASUS delivers a range of different configurations that will provide a cost effective solution.

Standard colours: White Powdercoat body - white or grey fascias. Other colours available on request.



technical

Common Modular Components*

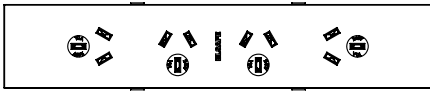

QF45 4GPO

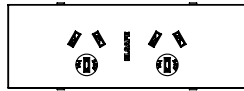

QF25 2GPO



QF35 2GPO 1TUF



Blank



AUNZ Data Cut-out



Keystone Data Cut-out



CAT6/CAT6a RJ45 Outlet



VGA



AUDIO



2 x RCA



3 x RCA

*see website for more

QF5 Tiles to provide Data and AV solutions

Expanded View

QF35

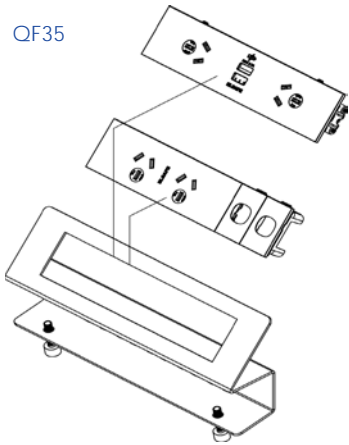

QF45

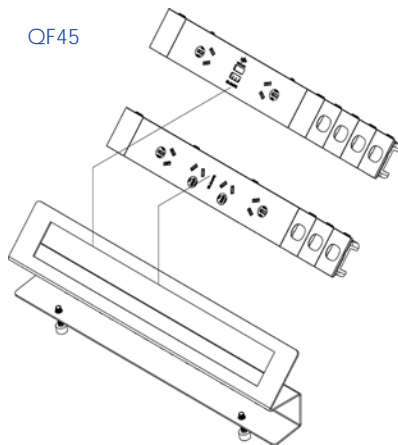

PEGASUS Sizes

Front View

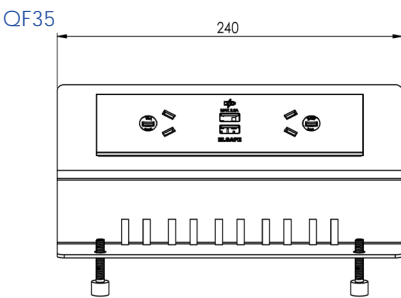

QF45

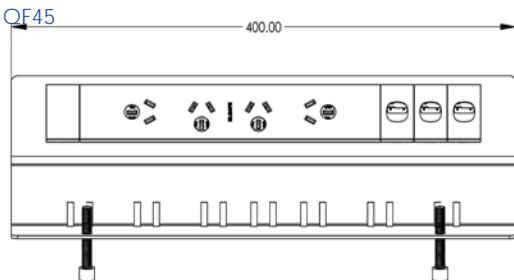

Side View

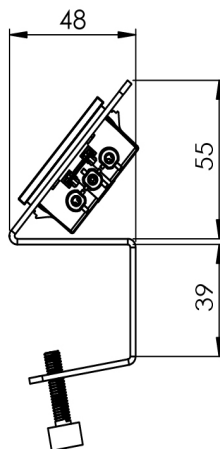

Features

Configuration:

Power only / Data only / Combined (Power, USB Charging & Data)

Insulation:

Reinforced insulation

Soft Wiring (Power):

Power hardwired to Wieland GST connector allows starter cables to be changed to suit requirements, especially useful during moves and changes (CHURN).

Soft Wired (Data):

As well as soft wired power, PEGASUS can be fitted with soft wired data.

Testing:

100% testing - continuity, polarity, insulation and earth.

Rating:

PEGASUS with Wieland GST entry are rated to 20Amp

Fixing Options:

QCB Standard Desk Bracket - finger tightened from under desk. Table thickness 15-35mm.

QF35

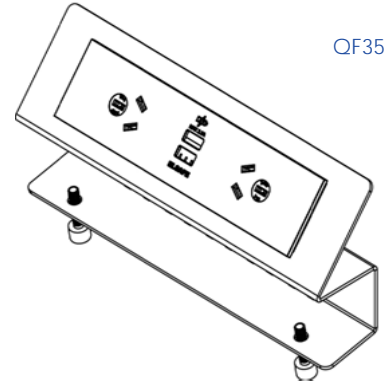

QF45

